



PNEUMATIC TOOLS

MODEL NO. SP522



ANGLE DIE GRINDER-REAR EXH.

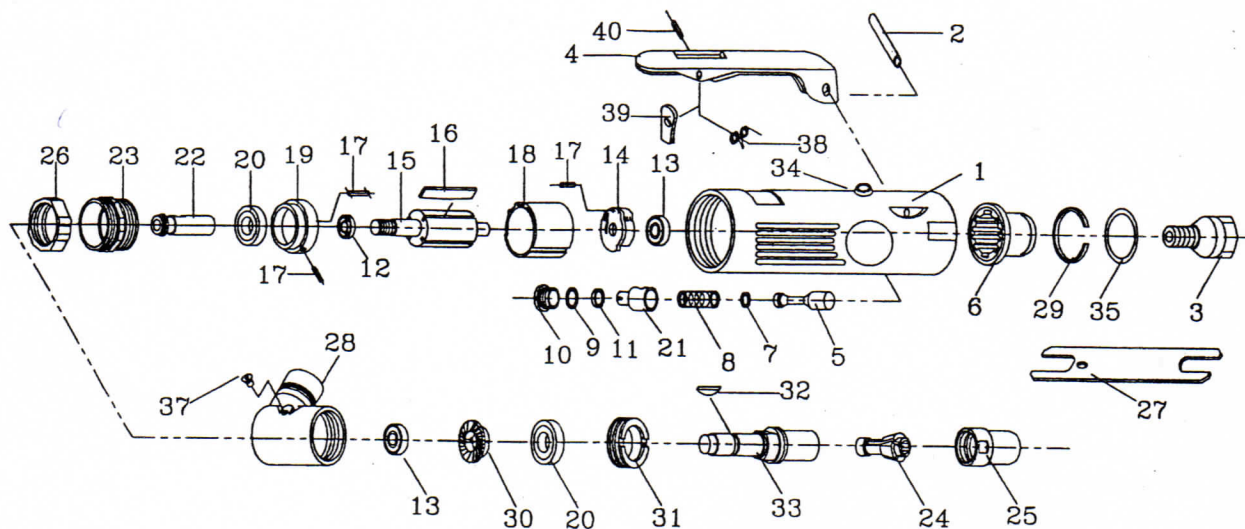

Index No.	Parts No.	Description
1	52201	Motor Housing
2	52202	Lever Pin
3	52203	Air Inlet
4	52204	Throttle Lever
5	52205	Valve Stem
6	52206	Deflector
7	52207	O-Ring
8	52208	Spring
9	52209	O-Ring
10	52210	Valve Screw
11	52211	O-Ring
12	52212	Rotor Spacer
13	52213	Ball Bearing(2)
14	52214	Rear Plate
15	52215	Rotor
16	52216	Rotor Blade(4)
17	52217	Pin(3)
18	52218	Cylinder
19	52219	Front Plate
20	52220	Ball Bearing(2)

Index No.	Parts No.	Description
21	52221	Contorller
22	52222	PINION Gear
23	52223	Front Coupling
24	52224	Collet
25	52225	Collet Nut
26	52226	Front Cap
27	52227	Spanner(2)
28	52228	Head
29	52229	Retaining Ring
30	52230	Bevel Gear
31	52231	Lock Ring
32	52232	Key
33	52233	Spindle
34	52234	Bushing
35	52235	O-Ring
37	52237	Oil Cap
38	52238	Spring
39	52239	Safety Bar
40	52240	Spring Pin